

● MCL-E10

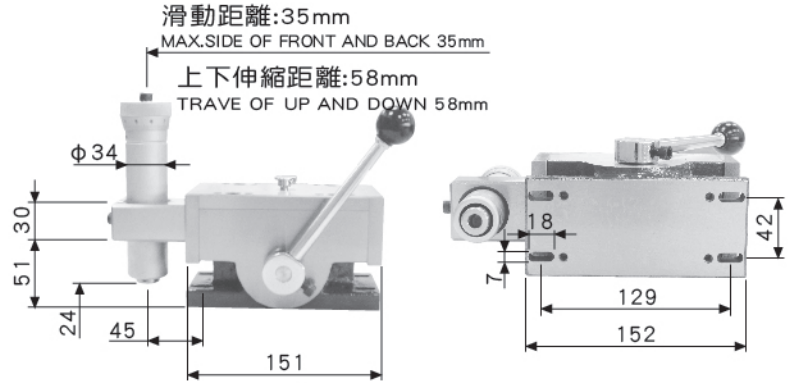
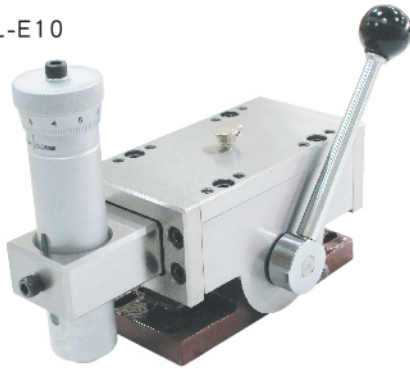

- 安裝於平面磨床主軸上來進行平行修整，比傳統修整器有較高的效率和方便性。
- 直線慣性滑動，可使修整砂輪更平順。
- 滑動軌間隙調整螺絲，位於滑動座中間，可使修整砂輪精確度更高。
- 修整管最小進刀量0.01mm(0.0005")。
- Thread forwards the slide to make dressing more smoothly.
- Adjustment screw is set between the slide and diamond cutter dead axle. It makes processing more easily, with high precision.
- Mainly E10 can do verprecision dressing, which can not be done by old model.
- Min scale of feed is 0.01mm(0.0005").

■ 配件:

1. 擋片一塊。
2. 鑽石筆1支。
3. M5六角扳手1支。
4. 六角承孔頭螺絲M6×10L×4支。
5. 六角頭螺絲1/4"-20UNC×25L×4支。
6. 華司×4個。

■ Accessory:

1. Block of stopper--- 1 piece
2. Diamond pen--- 1 piece
3. Hexagon type spanner 5MM--- 1 piece
4. M6 Screw--- 4 pieces
5. Hexagon screw 1/4"-20UNC×25L--- 4 pieces
6. Washer--- 4 pieces

訂購編號 Order No.	型號 Model	重量(kg) Weight
32085-10	MCL-E10(mm)	7.7
32085-15	MCL-E10(inch)	7.7

● MCL-E15

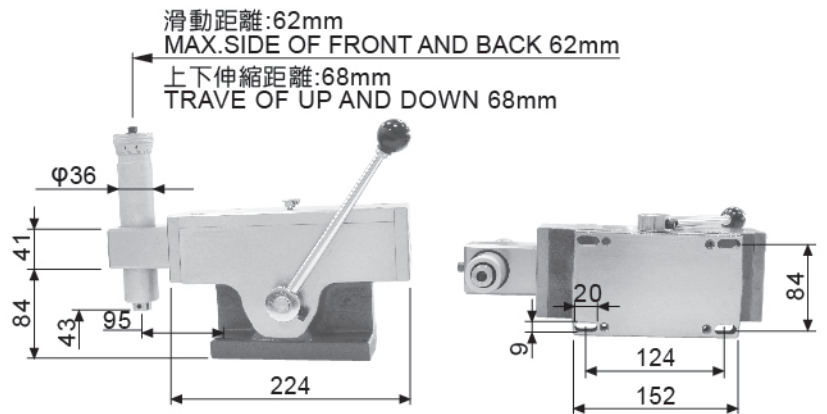
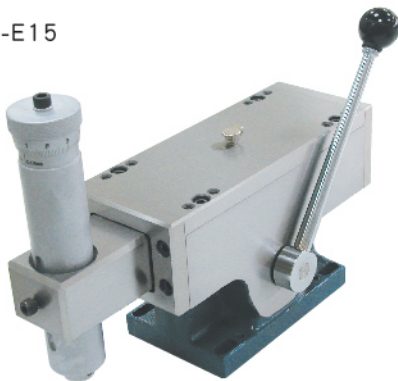

- 直線慣性滑動，可使修整砂輪更平順。
- 滑動軌間隙調整螺絲，位於滑動座中間，可使修整砂輪精確度更高。
- 修整管最小進刀量0.01mm(0.0005")。
- 滑動長度：約62mm。
- Thread forwards the slide to make dressing more smoothly.
- Adjustment screw is set between the slide and diamond cutter dead axle. It makes processing more easily, with high precision.
- Min. scale of feed is 0.01m/m(0.0005").
- Max.side of front and back 62mm.

■ 配件:

1. 上、下擋片各一塊
2. 擋片固定條×2支
3. φ10×35L鑽石筆1支
4. M5六角扳手1支
5. 六角承孔頭螺絲M6×20L×4支
6. 六角頭螺絲1/4"-20UNC×30L×4支
7. 華司×4個

■ Accessory:

1. Top and Bottom stopper block each--- 1 piece
2. Fixed batten for Stopper block--- 2 pieces
3. φ10×35L diamond pen--- 1 piece
4. Hexagon type spanner 5mm--- 1 piece
5. M6×20L Screw--- 4 pieces
6. HEXAGON SCREW 1/4"-20UNC×25L--- 4 pieces
7. Washer--- 4 pieces

訂購編號 Order No.	型號 Model	重量(kg) Weight
32085-20	MCL-E15(mm)	11.6
32085-25	MCL-E15(inch)	11.6