

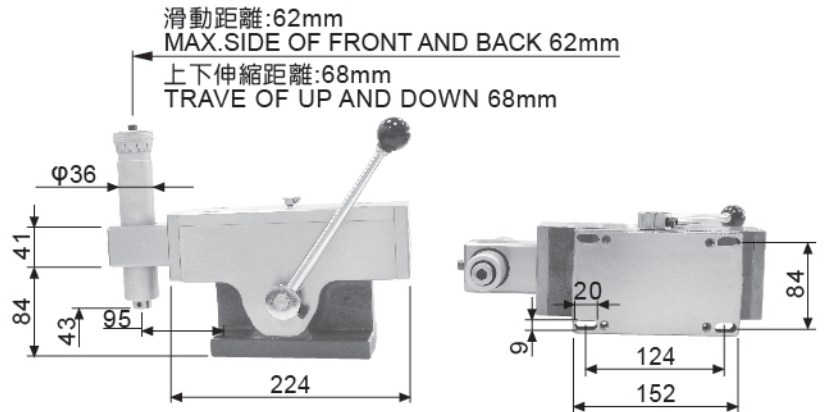

32085

砂輪平行修整器 PERIPHERAL ACCESSORIES FOR MACHINING CENTERS

● MCL-E15

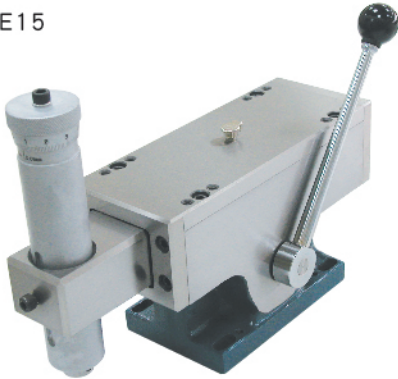

- 直線慣性滑動，可使修整砂輪更平順。
- 滑動軌間隙調整螺栓，位於滑動座中間，可使修整砂輪精確度更高。
- 修整管最小進刀量0.01mm(0.0005")。
- 滑動長度：約62mm。
- Thread forwards the slide to make dressing more smoothly.
- Adjustment screw is set between the slide and diamond cutter dead axle. It makes processing more easily, with high precision.
- Min. scale of feed is 0.01m/m(0.0005").
- Max.side of front and back 62mm.

■ 配件:

1. 上、下擋片各一塊
2. 擋片固定條×2支
3. φ10×35L鑽石筆1支
4. M5六角扳手1支
5. 六角承孔頭螺絲M6×20L×4支
6. 六角頭螺絲1/4"-20UNC×30L×4支
7. 華司×4個

■ Accessory:

1. Top and Bottom stopper block each--- 1 piece
2. Fixed batten for Stopper block--- 2 pieces
3. φ10×35L diamond pen--- 1 piece
4. Hexagon type spanner 5mm--- 1 piece
5. M6×20L Screw--- 4 pieces
6. HEXAGON SCREW 1/4"-20UNC x 25L--- 4 pieces
7. Washer--- 4 pieces

訂購編號 Order No.	型號 Model	重量(kg) Weight
32085-20	MCL-E15(mm)	11.6
32085-25	MCL-E15(inch)	11.6

32086

進刀管 FEED SHAFT

●報價均不含鑽石筆 DIAMOND PEN NOT INCLUDED



● φ34×0.01mm

● φ36×0.01mm

- 有公制與英制兩種規格，也可配合其他修整器使用。
- 進刀刻度(公制)0.01mm，(英制)0.005"。
- There are two specifications of metric and inch, which can be used with other dresser.
- Scale of Feed (metric)0.01mm (inch)0.005".

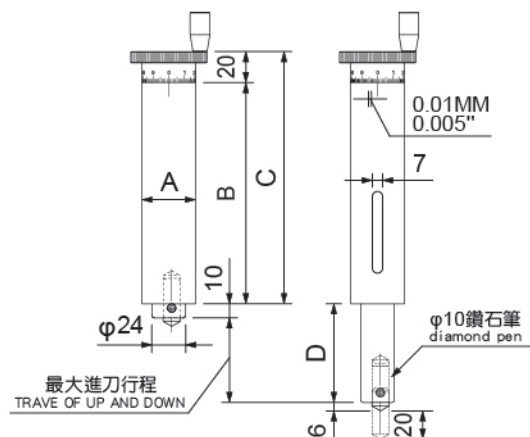

單位:mm

訂購編號 Order No.	型號 Model	A	B	C	D	刻度 Min. scale of feed	最大進刀行程 Trave of up to down	重量(kg) Weight
32086-34	E10-φ34(M)	34	120	140	20	0.01mm	24	0.9
32086-35	E10-φ34(I)	34	120	140	20	0.005"	24	0.9
32086-36	E15-φ36(M)	36	150	170	40	0.01mm	43	1.2
32086-37	E15-φ36(I)	36	150	170	40	0.005"	43	1.2