

### 32070

### 砂輪修整器 CONCAVE CONVEX FORMING DRESSER

● MCL-P55

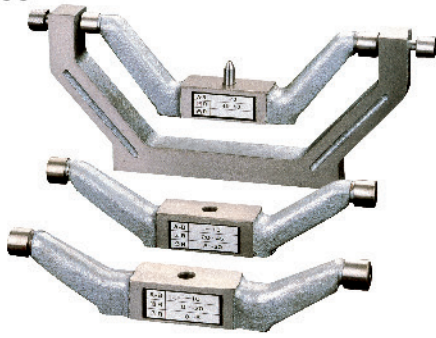

- 設計利用擺盪原理，由頂針固定中心點，前後擺盪修整。
- 操作簡易，利用高度規或高度游標卡尺可加減中心高度。
- 規格:
- 最大修整砂輪直徑:210mm(8")
- 小擺盪修整範圍:凸R 0.5~6mm。凹R 0.5~20mm
- 中擺盪修整範圍:凸R 0.5~20mm。凹R 20~45mm
- 大擺盪修整範圍:凸R 0.5~40mm。凹R 45~90mm
- 重量:6.2kg
- 配件:
- 1. 鑽石筆1支。
- 2. 固定頂針2支。

- Designed with principle of swing. Fixed the thimble by center, and dressed front and rear by swing.
- Easy to operate, use the height block or height caliper can add and subtract the height of center.

■Specifications:

- Maximum dressing diameter of grinding wheel:210mm(8")
- The dressing range of small swing:convex R 0.5~6mm。concave R 0.5~20mm
- The dressing range of middle swing:convex R 0.5~6mm。concave R 0.5~20mm
- The dressing range of large swing:convex R 0.5~40mm。concave R 45~90mm
- Weight:6.2kg

■Accessory:

1. Diamond pen--- 1 piece
2. Center for fixed--- 2 pieces

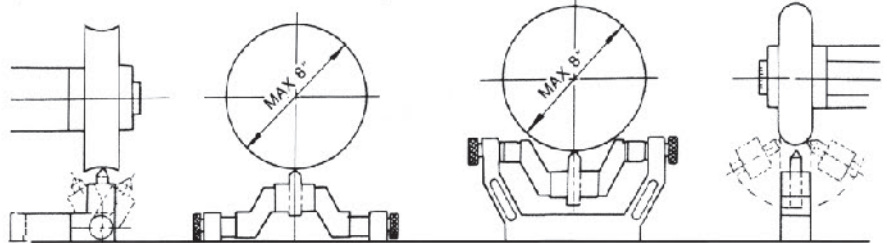

### 32085

### 砂輪平行修整器 PERIPHERAL ACCESSORIES FOR MACHINING CENTERS

● MCL-E10

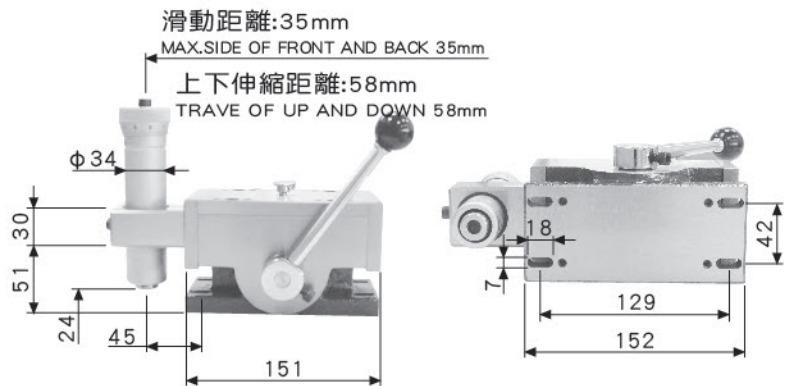
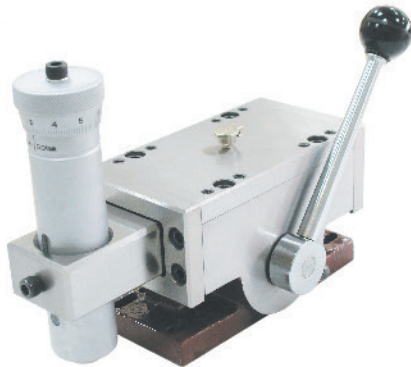

- 安裝於平面磨床主軸上來進行平行修整，比傳統修整器有較高的效率和方便性。
- 直線慣性滑動，可使修整砂輪更平順。
- 滑動軌間隙調整螺栓，位於滑動座中間，可使修整砂輪精確度更高。
- 修整管最小進刀量0.01mm(0.0005")。
- Thread forwards the slide to make dressing more smoothly.
- Adjustment screw is set between the slide and diamond cutter dead axle. It makes processing more easily, with high precision.
- Mainly E10 can do verprecision dressing, which can not be done by old model.
- Min scale of feed is 0.01mm(0.0005").

■配件:

1. 擋片一塊。
2. 鑽石筆1支。
3. M5六角扳手1支。
4. 六角承孔頭螺絲M6×10L×4支。
5. 六角頭螺絲1/4"-20UNC×25L×4支。
6. 華司×4個。

■Accessory:

1. Block of stopper--- 1 piece
2. Diamond pen--- 1 piece
3. Hexagon type spanner 5MM--- 1 piece
4. M6 Screw--- 4 pieces
5. Hexagon screw 1/4"-20UNC×25L--- 4 pieces
6. Washer--- 4 pieces

訂購編號 Order No.	型號 Model	重量(kg) Weight
32085-10	MCL-E10(mm)	7.7
32085-15	MCL-E10(inch)	7.7