

● MCL-C3 X 4

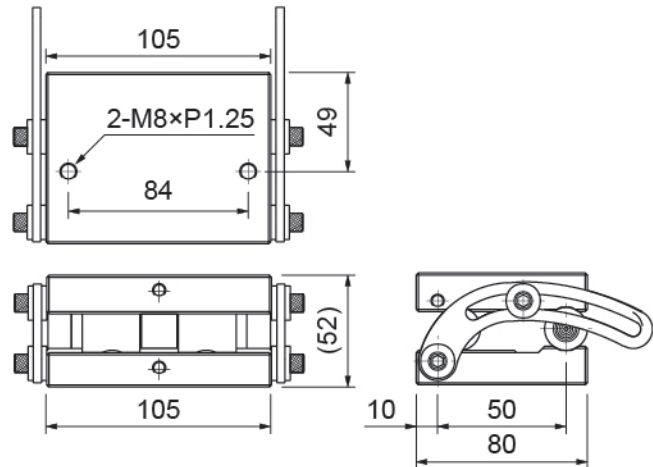
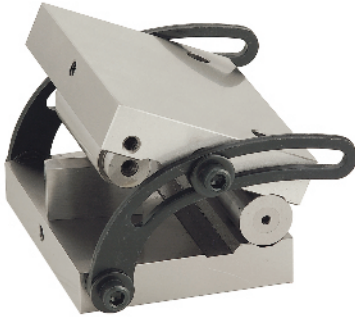

● 此款正弦座可配合沖子研磨器MCL-350.450.550.650 使用，固定於底座，輔助其正弦角度之功能。

● The sine plate can be set with punch former for swiveling mechanism. It makes your work more efficiency. The unit is suitable for MCL-350.450.550.650 series.

■ 規格:

■ Specifications:

- 材質：S50C
- 硬度：HRC55° ~57°
- 正弦中心距離：50mm / 4 μ 內
- 角度調整範圍：0~50度
- 平行精度：4 μ 內

- Material：S50C
- Hardness：HRC55° ~57°
- The distance of Sine center：50mm / 4 μ
- The adjusted range：0° ~50°
- Parallelism is within 4 μ

*** 正弦座應用示範 FOR EXAMPLE ***

